

可 _____

参 可

,* - 0 *10 -

* - *最1
- %0 *1 1* 优 0 *1 1*

可 * , -

* - *最

	* " " -				
-	2				
二	2	二			

		0 "0 " -		
	*			
	,			

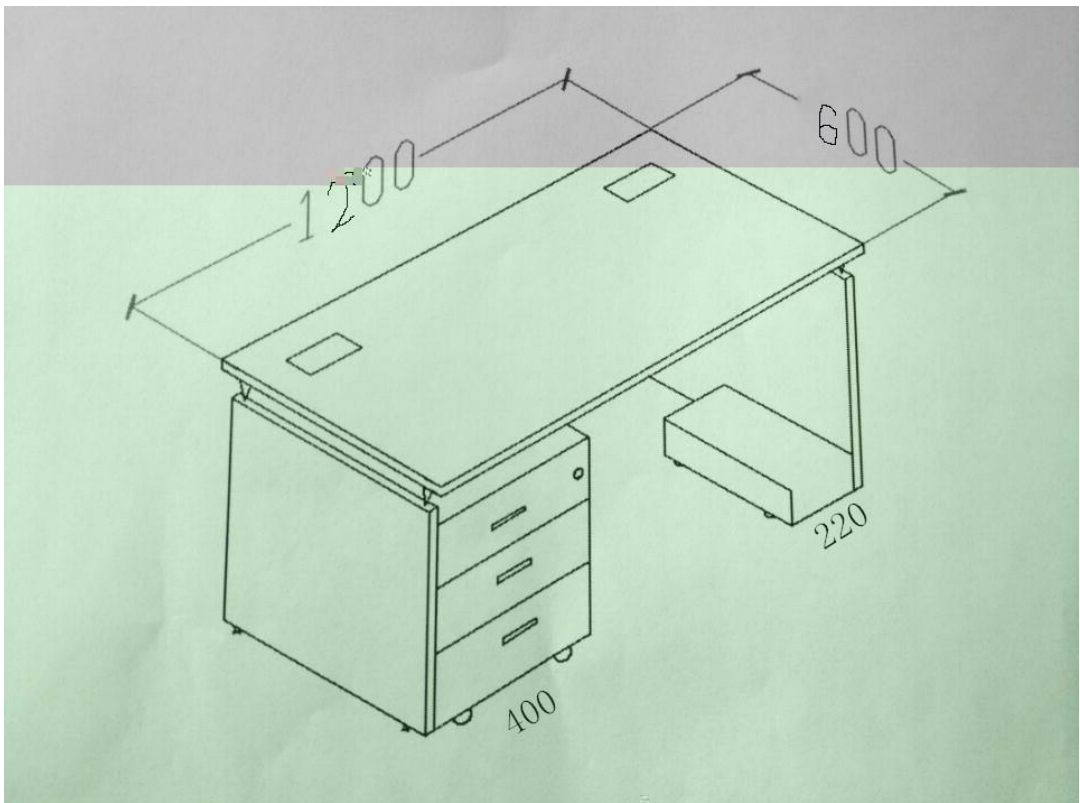

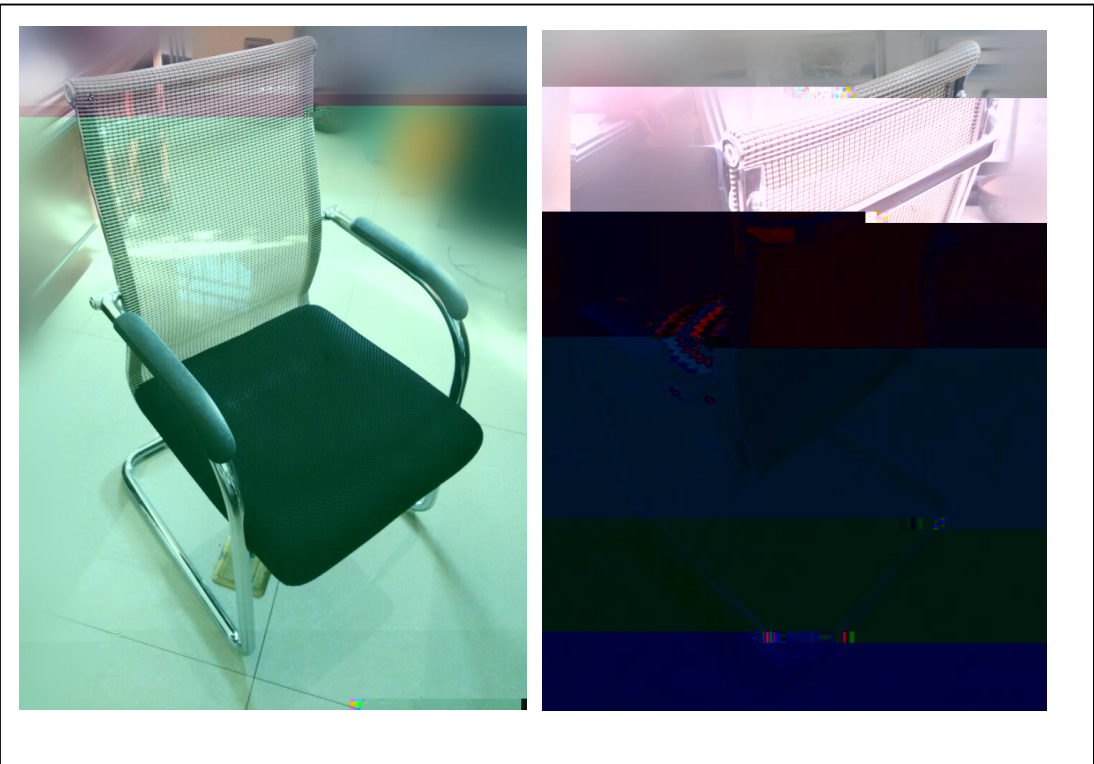



11

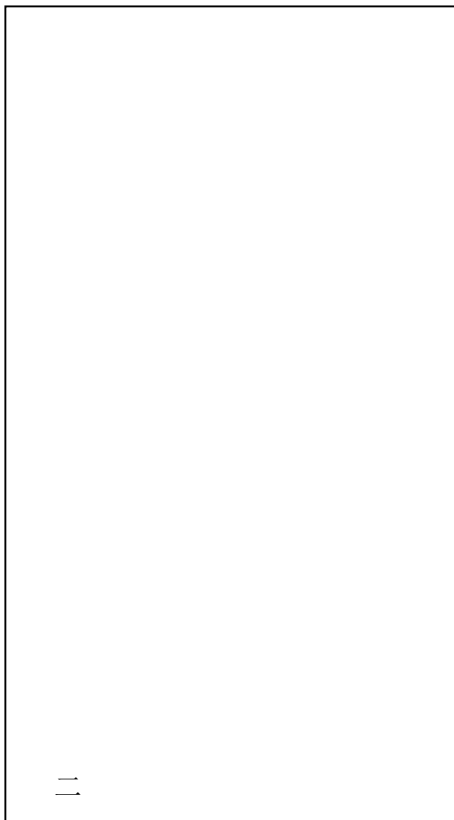

11

